

Архангельск (8182)63-90-72  
Астана (7172)727-132  
Астрахань (8512)99-46-04  
Барнаул (3852)73-04-60  
Белгород (4722)40-23-64  
Брянск (4832)59-03-52  
Владивосток (423)249-28-31  
Волгоград (844)278-03-48  
Вологда (8172)26-41-59  
Воронеж (473)204-51-73  
Екатеринбург (343)384-55-89  
Иваново (4932)77-34-06

Ижевск (3412)26-03-58  
Иркутск (395)279-98-46  
Казань (843)206-01-48  
Калининград (4012)72-03-81  
Калуга (4842)92-23-67  
Кемерово (3842)65-04-62  
Киров (8332)68-02-04  
Краснодар (861)203-40-90  
Красноярск (391)204-63-61  
Курск (4712)77-13-04  
Липецк (4742)52-20-81

Магнитогорск (3519)55-03-13  
Москва (495)268-04-70  
Мурманск (8152)59-64-93  
Набережные Челны (8552)20-53-41  
Нижний Новгород (831)429-08-12  
Новокузнецк (3843)20-46-81  
Новосибирск (383)227-86-73  
Омск (3812)21-46-40  
Орел (4862)44-53-42  
Оренбург (3532)37-68-04  
Пенза (8412)22-31-16

Пермь (342)205-81-47  
Ростов-на-Дону (863)308-18-15  
Рязань (4912)46-61-64  
Самара (846)206-03-16  
Санкт-Петербург (812)309-46-40  
Саратов (845)249-38-78  
Севастополь (8692)22-31-93  
Симферополь (3652)67-13-56  
Смоленск (4812)29-41-54  
Сочи (862)225-72-31  
Ставрополь (8652)20-65-13

Сургут (3462)77-98-35  
Тверь (4822)63-31-35  
Томск (3822)98-41-53  
Тула (4872)74-02-29  
Тюмень (3452)66-21-18  
Ульяновск (8422)24-23-59  
Уфа (347)229-48-12  
Хабаровск (4212)92-98-04  
Челябинск (351)202-03-61  
Череповец (8202)49-02-64  
Ярославль (4852)69-52-93

Киргизия (996)312-96-26-47

Россия (495)268-04-70

Казахстан (772)734-952-31

<https://nock.nt-rt.ru/> || [nck@nt-rt.ru](mailto:nck@nt-rt.ru)



## Doner and Gyros cutting machines

A cut above the rest!

## Top quality – Made in Germany

NOCK is an owner run German family business, which since 1990 constructs and successfully sells modern machines for the meat processing industry worldwide. Having a close business working relationship with meat processing plants and distributors worldwide, the machines are constantly further developed and improved. Needless to say, the highest hygiene and safety standards are our main concern.



*F. Nock*

Ferdinand Nock,  
company founder

NOCK stands for uncompromising quality “Made in Germany”. This begins with the quality-orientated concept and construction of the NOCK cutting machines, comprising of the manufacturing of all central components at the company-own ultra-modern machine park, exclusively using premium base materials and acquired parts, the collaboration with established suppliers, diligent assembling and final inspection of the NOCK machines. An experienced team of highly qualified and motivated employees also contributes significantly to this high quality standard. This results in modern, particularly reliable and durable machines of continuous quality.



Modern, intelligent production methods, modular construction technique and a strict cost controlling enable NOCK to provide machinery of high German quality at affordable prices – an interesting aspect for the food processing plants which often have tight investment budgets.



## Be a cut above the rest with a NOCK Doner or Gyros cutting machine!

### Better and more economical than a common derinder!

Due to a lack of information a derinding machine is often falsely applied to cut Doner or Gyros meat slices. However this is a makeshift solution as the meat is highly strained and a good cut quality will not be attained.

Indeed the NOCK Doner and Gyros cutting machines are technically similar to the derinders. However they have been **especially further developed to cut meat slices.**

Important differences in comparison to the NOCK derinders are for example:

- softer pressure wheels
- softer springs in the pressure unit
- modified transport roller (tooth roller)
- modified blade holder with special springs
- larger adjustment range of the blade gap (standard 0.5 - 8 mm)

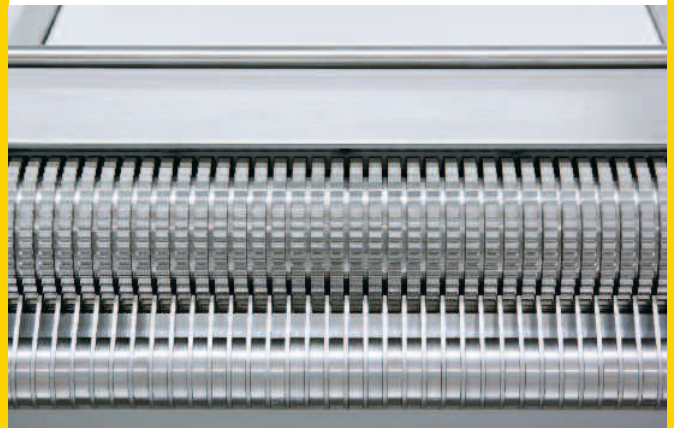

### Your benefits:

- very smooth cut, also with thin slices
- gentle processing of the meat
- large range of possible cutting widths (e.g. thick slices for Yaprak Doner and thin slices for mincemeat Doner)

Last but not least the NOCK Doner and Gyros cutting machines can be purchased with the beneficial **NOCK Integrated Product Return System®**. This does not require any extra space, is very good value and considerably reduces the production costs.



## The NOCK Integrated Product Return System®

### Fast return of investment

The NOCK Integrated Product Return System® is an optional equipment for the NOCK Doner and Gyros cutting machines, which makes the production of Doner and Gyros meat slices **faster and even more economical**.

### The function:

The operator places the meat on the infeed conveyor belt. The meat moves through the machine and the first slice is cut. The remaining piece comes automatically back and lands on top of the small surface above the infeed conveyor belt. The returned piece is then reapplied to the infeed conveyor belt. This process can be repeated until there is no remaining piece to be cut. Generally it is possible to process two large or up to four small pieces simultaneously.

**The laborious retrieving of the remaining meat pieces from the back of the machine is not necessary.**

### The benefits:

- **no second operator** required to retrieve the remaining pieces = saves costs
- the operator must not interrupt the processing to retrieve the remaining pieces = **larger production amounts per hour**
- prevention of backache for the operator (no need to bend down)
- **small space required** for the complete machine as there is no need for a separate external return conveyor belt
- the machine can be positioned against a wall
- quickly and easily cleaned
- **good value! Fast return of investment!**



Breast of veal on a Doner cutting machine Cortex CB 503 KEBAB with NOCK Integrated Product Return System®

## Cortex CB 503 KEBAB • CB 703 KEBAB

### Features and application range

- machine with large cutting width to gently slice high quality meat slices for Doner kebab and Gyros meat skewers (Yaprak makinasi)
- cutting width: 500/700 mm
- cutting speed: 28 m/min
- ideally suited to cut not only breast of veal and bull meat, but also suitable for turkey breast, pork and lamb
- large adjustment range of blade gap. Through this the same blade holder can also be used to cut slices for not only Yaprak Doner but also for mincemeat Doner.

### Standard equipment

- underframe open on all four sides for simple placing and removing of containers from all sides
- blade gap infinitely adjustable from 0.5 - 8 mm (even when the machine is in operation)
- blade holder suspended with special springs
- pressure unit equipped with soft pressure wheels and with special springs
- pressure roller infinitely adjustable in height
- transport roller with peripheral grooves (tooth roller and scraper comb)
- infeed conveyor
- NOCK EASY-FLOW® safety cover
- NOCK POWER PLATES® for particular robustness and service friendliness
- lockable steering castors
- stainless steel
- stainless steel ball bearings



*Cortex CB 503 KEBAB with NOCK Integrated Product Return System® (optional)*



*Cortex CB 503 KEBAB with output conveyor for the sliced meat (optional)*

### Options:

- NOCK Integrated Product Return System® (highly recommendable!)
- output conveyor for sliced meat (to fill large containers, e.g. for meat trolleys)
- output conveyor for remaining piece (not possible with NOCK Integrated Product Return System®)
- blade holder with other thickness ranges (e.g. 4 - 12 mm)
- multi-cut lines

# Cortex CB 496 GYROS

## Features and application range

- machine with smaller cutting width to gently slice high quality meat slices for Gyros and for Doner kebab meat skewers, also for stir-fry dishes
- cutting width: 430 mm
- cutting speed: 24 m/min
- to cut all pork pieces (ribs, necks, shoulder, etc) and to cut all other meat types, e.g. breast of veal (in pieces), turkey breast, lamb
- large, infinite adjustment range of the blade

## Standard equipment

- blade gap infinitely adjustable from 0.5 - 8 mm (even when the machine is in operation)
- blade holder suspended with special springs
- pressure unit equipped with soft rubber wheels and with softer springs
- pressure unit infinitely adjustable in height
- transport roller with peripheral grooves (tooth roller) and scraper comb
- infeed conveyor
- NOCK EASY-FLOW® safety cover
- NOCK POWER PLATES® for particular robustness and service friendliness
- lockable steering castors
- stainless steel
- stainless steel ball bearings



Cortex CB 496 GYROS with NOCK Integrated Product Return System® (optional)



Cortex CB 496 GYROS with NOCK EASY-FLOW® safety cover and optional output conveyor for remaining uncut piece

## Options:

- NOCK Integrated Product Return System® (highly recommendable!)
- output conveyor for sliced meat (to fill large containers, e.g. for meat trolleys)
- output conveyor for remaining uncut piece (not possible with the NOCK Integrated Product Return System®)
- blade holder with other thickness ranges (e.g. 7 - 15 mm)
- spring stiffness of the pressure unit depending on product
- multi-cut lines

## Multi-cut lines



*Cutting line Cortex CB 503 KEBAB SEPTO with output conveyor for sliced meat*

### Features and application range

- multi-cut lines to cut high quality meat slices for Doner kebab or Gyros meat skewers

The system is made up of modular linked single machines Cortex CB 503 KEBAB/CB 703 KEBAB or Cortex CB 496 GYROS for 2 - 7 successive, automatic cutting processes (DUO, TRIO, QUATTRO, CINCO, SIXTO, SEPTO)

- cutting widths: 430 / 500 / 700 mm
- cutting speed: 24 / 28 m/min
- to cut very large meat amount from veal, bull beef and pork with very low personnel cost
- each machine can be removed and operated individually
- simple decoupling / coupling of the machines for cleaning and restarting
- blade gap (thickness of slices) of each machine individual adjustable

### Standard equipment

The standard equipment of each machine is equal to the equipment of the single version. The machines are simply modified for coupling.

- blade gap infinitely adjustable of 0.5 - 8 mm (even when the machine is in operation)
- blade holder equipped with special springs
- pressure unit equipped with soft rubber wheels and suspended with special springs
- pressure unit infinitely adjustable in height
- transport roller with peripheral grooves (tooth roller) and scraper comb
- infeed conveyor
- NOCK EASY-FLOW® safety cover
- NOCK POWER PLATES® for particular robustness and service friendliness
- lockable steering castors
- stainless steel
- stainless steel ball bearings



*Cutting line Cortex CB 503 KEBAB TRIO with output conveyor for sliced meat*

### Options:

- a long output conveyor with elevating belt positioned underneath the machines for filling cut meat into large containers, e.g. meat trolleys
- output conveyor on hindmost machine for remaining uncut piece
- output slide sheet for each machine for single use

## Solid. Sturdy. Durable: The NOCK POWER PLATES®



The mechanically highly strained machine components such as drive, transport roller, blade holder and pressure device are mounted in solid, **15 mm thick base plates**, the **NOCK POWER PLATES®**, which are located in the machine casing. In comparison to the mounting of these parts directly onto the casing, this construction has proven itself since 1990 in thousands of NOCK machines and has the following deciding advantages:

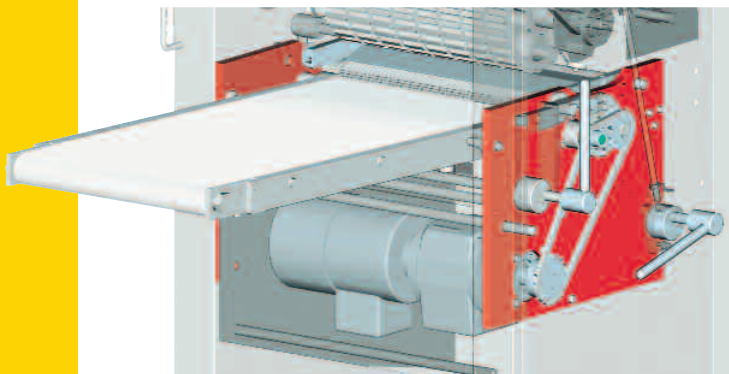

### ■ Long lasting precision

The NOCK POWER PLATES® guarantee an excellent bearing alignment and precise positioning of the machine parts. And thereby a constant better function of the machines.

### ■ No material fatigue

When the highly strained parts of a machine are positioned on the casing, sooner or later it can come to deformation or crevices. With a 15 mm thickness, the NOCK POWER PLATES® are resistant to material fatigue. This has been proven by thousands of NOCK machines since 1990 in the hardest industrial operation, even in several shift operation. The NOCK POWER PLATES® make the machines particularly sturdy and durable.

### ■ Service friendliness

All components are very easily accessible once the side covers are opened.

### ■ Hygienic and easy to clean machine surfaces

Due to the positioning of the machine components on the NOCK POWER PLATES®, the steel casing can be designed with large smooth surfaces. This makes the NOCK machines particularly hygienic and easy to clean.

## Quick cleaning and optimum hygiene

The NOCK Doner and Gyros cutting machines have not only a modern, but also a **hygienic design**, which certainly complies with the latest hygienic regulations.

The machine casing, conveyor belt frame, transport roller, blade holder etc. are made of **high quality stainless steel**.

The conveyor belts and pressure rollers are made of approved food-grade plastics.

Due to the NOCK POWER PLATES® it is possible to construct the casings of the machines with **large smooth surfaces** which are particularly hygienic and easy to clean.

The tunnel-like constructed **NOCK EASY-FLOW® safety cover** and the corresponding cover of the NOCK Integrated Product Return System® prevent to a large extent the build-up of product surpluses on the mountings of the blade holder and pressure unit during processing.

All NOCK cutting machines are equipped with lockable steering castors. This eases transportation to the cleaning area.



Conveyor belts, pressure roller, blade holder and output slide sheet can be removed and replaced for cleaning purposes within seconds without any tools. Therefore soiled parts are easily accessible. The transport roller can be turned by hand. The conveyor belt frames can be folded back so that the inside of the belts can be cleaned. The conveyor belts can also be easily removed from their frames for thorough cleaning.

**Ball bearings made of stainless steel** are more resistant to improper cleaning of the machines.



### Quick and easy to clean:

NOCK cutting machine after removing conveyor belt, pressure roller and blade holder. Scraper comb folded back

## Technical data + equipment / Doner and Gyros cutting machines

	Cortex CB 503 KEBAB	Cortex CB 703 KEBAB	Cortex CB 496 GYROS
cutting width (mm)	500	700	430
cutting speed (m/min)	28	28	24
NOCK Integrated Product Return System®	<input type="checkbox"/>	<input type="checkbox"/>	<input type="checkbox"/>
alternative: output conveyor for remaining uncut piece	<input type="checkbox"/>	<input type="checkbox"/>	<input type="checkbox"/>
output conveyor for sliced meat	<input type="checkbox"/>	<input type="checkbox"/> ④	<input type="checkbox"/>
plastic modular belts	<input type="checkbox"/>	<input type="checkbox"/>	<input type="checkbox"/>
pressure roller spring suspended adjustable in height	<input checked="" type="checkbox"/>	<input checked="" type="checkbox"/>	<input checked="" type="checkbox"/>
blade gap infinitely adjustable (mm)	0.5 – 8 ①	0.5 – 8 ①	0.5 – 8 ①
apply length on infeed conveyor (mm)	400 ③	400 ③	400 ③
tooth roller with scraper comb	<input checked="" type="checkbox"/>	<input checked="" type="checkbox"/>	<input checked="" type="checkbox"/>
blade holder spring suspended	<input checked="" type="checkbox"/>	<input checked="" type="checkbox"/>	<input checked="" type="checkbox"/>
max. throughput height (mm)	90	90	90
lockable steering castors	<input checked="" type="checkbox"/>	<input checked="" type="checkbox"/>	<input checked="" type="checkbox"/>
NOCK POWER PLATES®	<input checked="" type="checkbox"/>	<input checked="" type="checkbox"/>	<input checked="" type="checkbox"/>
motor performance (kW)	1.1	1.1	0.75
electrical connection	3 AC - 400 V – 50 Hz ②		
weight (kg)	235 ③	300 ③	210 ③
overall dimension W x H x D (mm)	980 x 1190 x 1360 ③	1065 x 1190 x 1360 ③	910 x 1190 x 1210 ③
stainless steel	<input checked="" type="checkbox"/>	<input checked="" type="checkbox"/>	<input checked="" type="checkbox"/>
stainless steel ball bearings	<input checked="" type="checkbox"/>	<input checked="" type="checkbox"/>	<input checked="" type="checkbox"/>
available as a multi-cut line	<input type="checkbox"/>	<input type="checkbox"/>	<input type="checkbox"/>

① optional: other thickness ranges

② other voltages upon request

③ with NOCK Integrated Product Return System®, without output conveyor for sliced meat

④ not necessary because a standard trolley (USDA/DIN 9797) can be placed below the machine

standard

optional

Архангельск (8182)63-90-72

Астана (7172)727-132

Астрахань (8512)99-46-04

Барнаул (3852)73-04-60

Белгород (4722)40-23-64

Брянск (4832)59-03-52

Владивосток (423)249-28-31

Волгоград (844)278-03-48

Вологда (8172)26-41-59

Воронеж (473)204-51-73

Екатеринбург (343)384-55-89

Иваново (4932)77-34-06

Ижевск (3412)26-03-58

Иркутск (395)279-98-46

Казань (843)206-01-48

Калининград (4012)72-03-81

Калуга (4842)92-23-67

Кемерово (3842)65-04-62

Киров (8332)68-02-04

Краснодар (861)203-40-90

Красноярск (391)204-63-61

Курск (4712)77-13-04

Липецк (4742)52-20-81

Магнитогорск (3519)55-03-13

Москва (495)268-04-70

Мурманск (8152)59-64-93

Набережные Челны (8552)20-53-41

Нижний Новгород (831)429-08-12

Новокузнецк (3843)20-46-81

Новосибирск (383)227-86-73

Омск (3812)21-46-40

Орел (4862)44-53-42

Оренбург (3532)37-68-04

Пенза (8412)22-31-16

Пермь (342)205-81-47

Ростов-на-Дону (863)308-18-15

Рязань (4912)46-61-64

Самара (846)206-03-16

Санкт-Петербург (812)309-46-40

Саратов (845)249-38-78

Севастополь (8692)22-31-93

Симферополь (3652)67-13-56

Смоленск (4812)29-41-54

Сочи (862)225-72-31

Ставрополь (8652)20-65-13

Сургут (3462)77-98-35

Тверь (4822)63-31-35

Томск (3822)98-41-53

Тула (4872)74-02-29

Тюмень (3452)66-21-18

Ульяновск (8422)24-23-59

Уфа (347)229-48-12

Хабаровск (4212)92-98-04

Челябинск (351)202-03-61

Череповец (8202)49-02-64

Ярославль (4852)69-52-93

Киргизия (996)312-96-26-47

Россия (495)268-04-70

Казахстан (772)734-952-31

<https://nock.nt-rt.ru/> || [nck@nt-rt.ru](mailto:nck@nt-rt.ru)